

DESCRIPTION

The MMA01-1002 is an accessory input/output (I/O) board with four isolated inputs, two isolated outputs, and a CAN (controller area network) interface. It is designed to be used together with EZmotion's PCN series motor driver modules.

The MMA01-1002 integrates four isolated input ports for control signal inputs, and two isolated output ports for status signal outputs. It also features a CAN interface for field bus connection, a USB port for parameter configuration and system debugging, and LED indicators to show the system, fuse, and other necessary circuit statuses.

The MMA01-1002 can be connected to any of EZmotion's PCN series motor driver modules to work as a ready-to-use motor driver solution.

FEATURES

- 12V to 75V Input Voltage (V_{IN}) Range
- CAN Interface for Field Bus Connection
- 4 Isolated Digital Signal Inputs
- 2 Isolated Digital Signal Outputs
- USB Port for Parameter Configuration and System Debugging
- LED Status Indication for PWR, ERR, and BUS
- 0°C to 70°C Operating Temperature (Power Derated > 40°C)
- -20°C to +55°C Storage Temperature

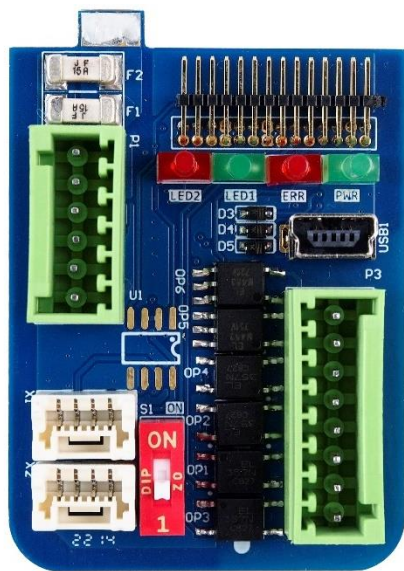

Top View

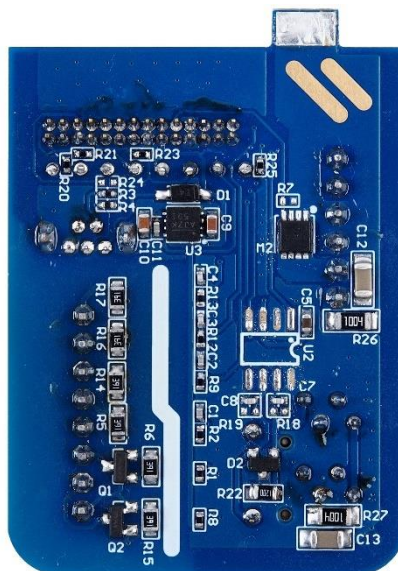

Bottom View

PRODUCT INFORMATION

Part Number	Number of Digital Inputs	Number of Digital Outputs	Field Bus Interface
MMA01-1002	4 isolated	2 isolated	CAN

ACCESSORIES

The MMA03-4001 connector suite contains connectors and crimp terminals, which allows the user to connect EZmotion motors driver modules to the power supply, field bus, and I/O interface. The connectors provided with the MMA03-4001 match with those for the MMA01-1002. Refer to the MMA03-4001 datasheet for more details.

Part Number	Component	Description	Quantity
MMA03-4001	KF12EKD-2.5-6P-1G	2.5mm pitch, 6-position connector	1
	KF12EKD-2.5-8P-1G	2.5mm pitch, 8-position connector	1
	ZER-04V-S	1.5mm pitch, 4-position connector	2
	SZE-002T-P0.3	Socket contact tin 24-28 AWG crimp	8

PRODUCT SPECIFICATIONS

Parameter	Conditions	Value	Units
Electrical Rating			
DC input voltage (V_{IN})		12 to 75	V
Continuous DC input current (I_{IN})	0°C to 40°C	10	A
Maximum digital output load current (I_{DO_MAX})		100	mA
Maximum digital output voltage (V_{DO_MAX})		36	V
Digital input logic high voltage (V_{DI})		15 to 28	V
DI1+, DI2+ pulse frequency		<500	kHz
DI1+, DI2+ minimum pulse width		1	μs
DI3+, DI4+ pulse frequency		<10	kHz
DI3+, DI4+ minimum pulse width		20	μs
Other logic pin voltage range		-0.3 to +3.6	V
Interfaces			
CAN baud rate		Max 1	Mbps
USB 2.0		Mini USB Type-B, full speed	

RECOMMENDED OPERATING CONDITIONS

Input voltage (V_{IN}) 12V to 75V
 CAN_H/CAN_L voltage..... ±15V
 CAN common-mode voltage..... -7 to +12V
 Operation temperature..... 0°C to 70°C
 Storage temperature -20°C to +55°C

HARDWARE CONNECTIONS

The MMA01-1002 should be used together with the PCN series motor driver module(s) to drive a servo motor. Plug the MMA01-1002 into the driver module for a ready-to-use motor driver solution (see Figure 1).

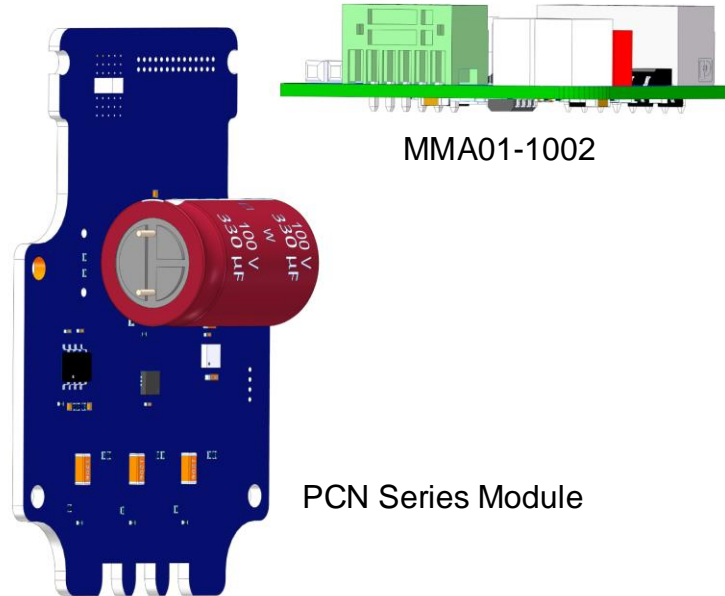
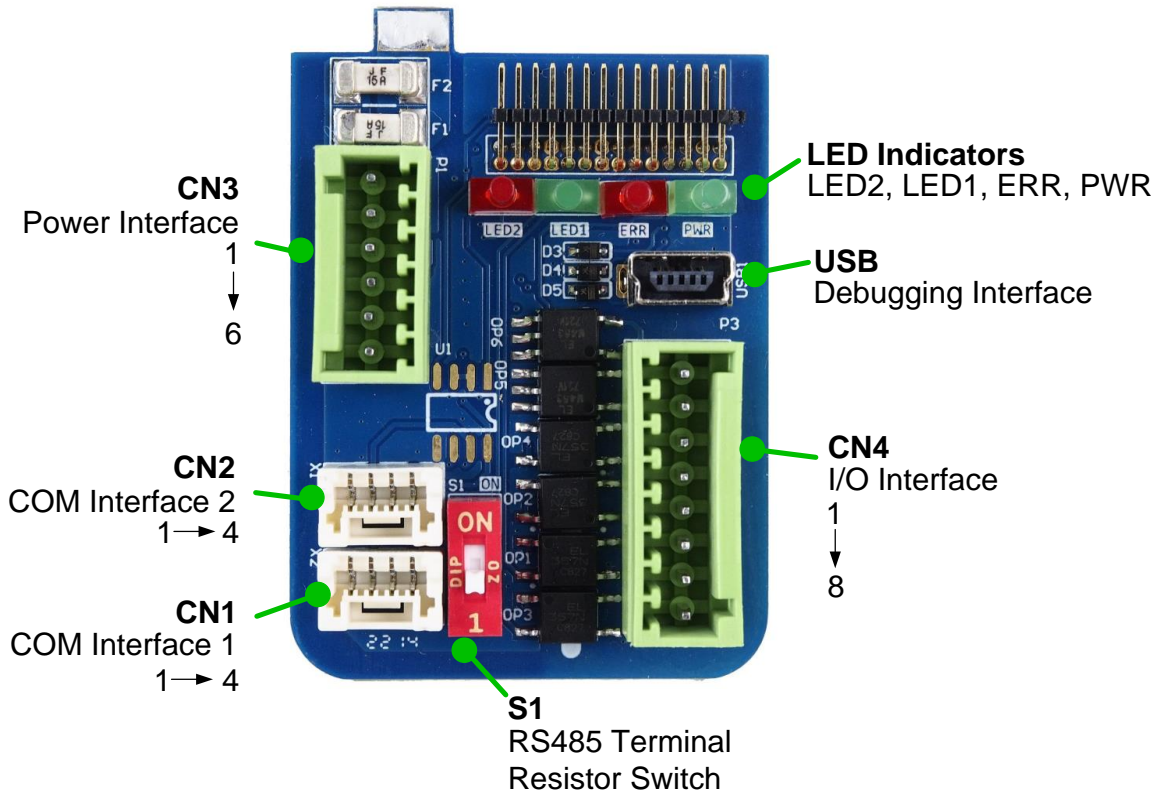

Figure 1: Assembled Motor Driver Module with MMA01-1002 Board

PIN CONFIGURATION

MMA01-1002 Pin Definitions
Communication Interface (CN1, CN2)

Pin #	Designation	Pin Description
1	SHIELD	Shield.
2	CAN_L	CAN interface CAN_L signal terminal.
3	GND	Ground.
4	CAN_H	CAN interface CAN_H signal terminal.

Power Interface (CN3)

Pin #	Designation	Pin Description
1	VIN	Input power supply.
2	VIN	Input power supply.
3	GND	Power ground.
4	GND	Power ground.
5	R-	Brake resistor return node.
6	PE	Earth ground.

I/O Interface (CN4)

Pin #	Designation	Pin Description
1	DI1+	Input IO1, default DIR.
2	DI2+	Input IO2, default PUL.
3	DI3+	Input IO3, default ENA.
4	DI4+	Input IO4.
5	COMI	Common input return.
6	DO1+	Output IO1, default ALARM.
7	DO2+	Output IO2, default PEND.
8	COMO	Common output return.

Figure 2 shows the I/O interface internal circuit. The digital input signals have a common input terminal, and the digital output signals have a common output terminal.

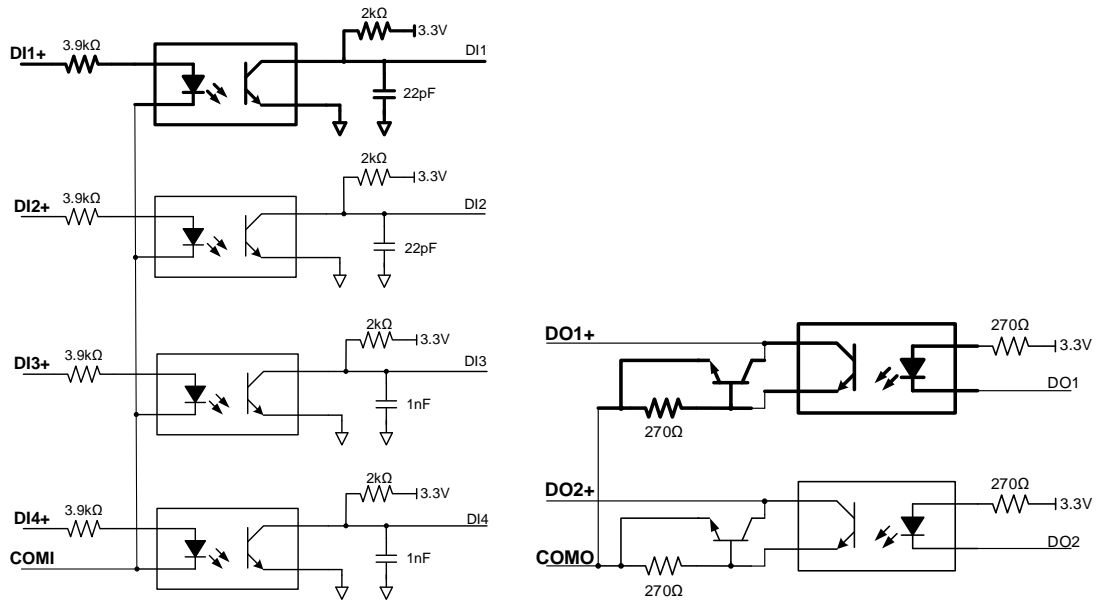
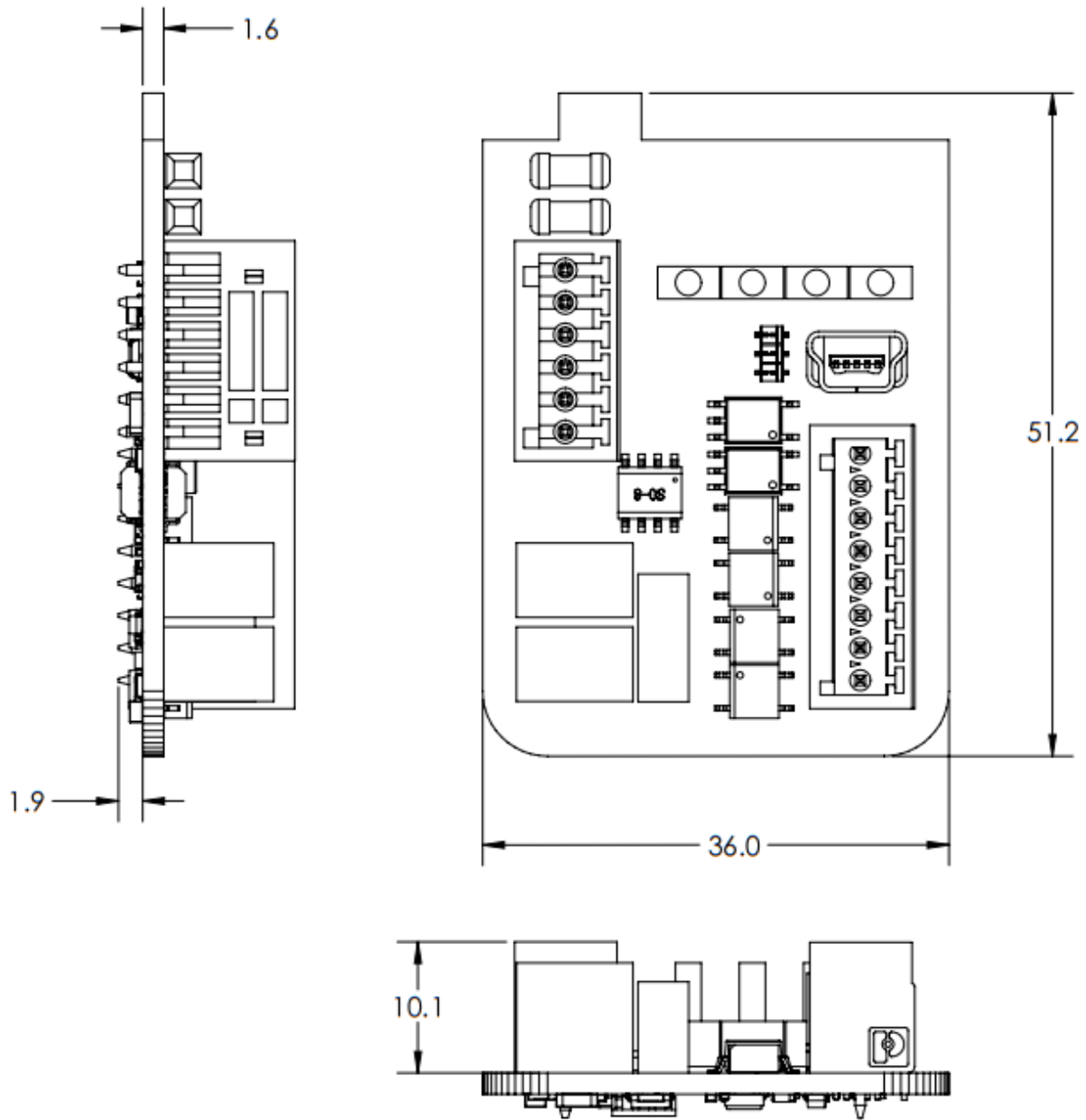

Figure 2: I/O Interface Internal Circuit

LED Indicators

Pin #	Designation	Pin Description
1	LED2	Communication status 2.
2	LED1	Communication status 1.
3	ERR	Error indicator.
4	PWR	Power indicator.

MECHANICAL DRAWING (1)



Note:

1) Units are in mm.

REVISION HISTORY

Revision #	Revision Date	Description	Pages Updated
1.0	2/6/2023	Initial Release	-

Notice: The information in this document is subject to change without notice. Please contact EZmotion for current specifications. Users should warrant and guarantee that third-party Intellectual Property rights are not infringed upon when integrating EZmotion products into any application. EZmotion will not assume any legal responsibility for any said applications.